

REROSA-HYDRAULIKA, s.r.o.

Typ/Type
VBCB

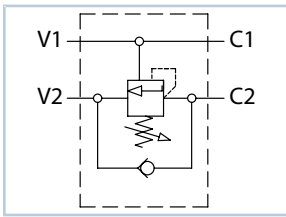

Dati tecnici Technical data	
Viscosità fluido Fluid viscosity	10-500 mm ² /s 45 to 2000 ssu (6 to 420 cSt)
Classe di contaminazione Filtration	ISO code 16/13 SAE class 4 or better
Temperatura fluido Fluid temperature	-20°C +80°C -4°F +176°F
Temperatura ambiente Ambient temperature	-20°C +50°C -4°F +122°F
Settaggio valvola di massima: almeno 1,3 volte il carico più alto usato. Relief valve setting: at least 1.3 times the highest expected load.	

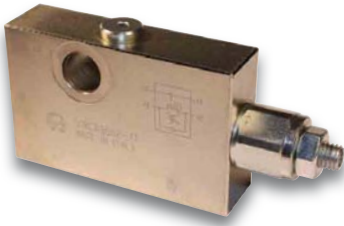
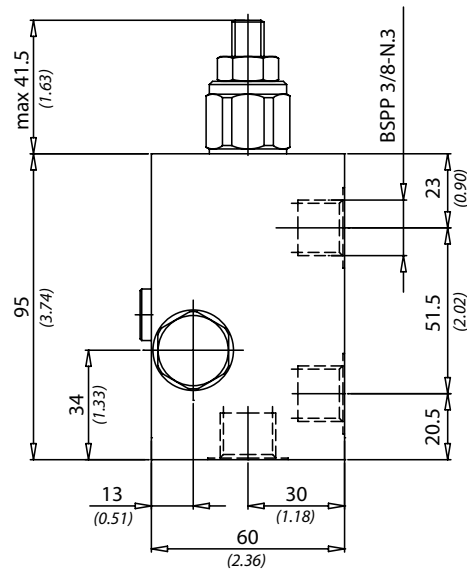
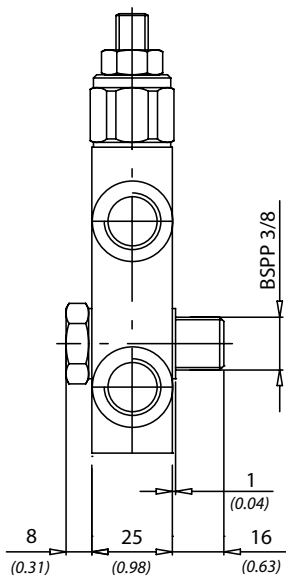
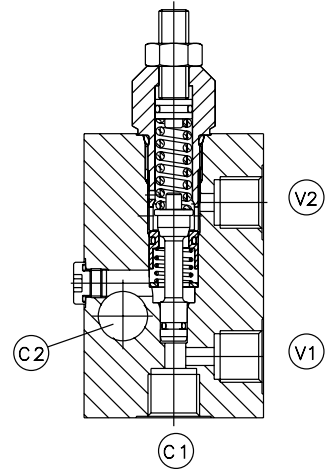

mm
(Inches)

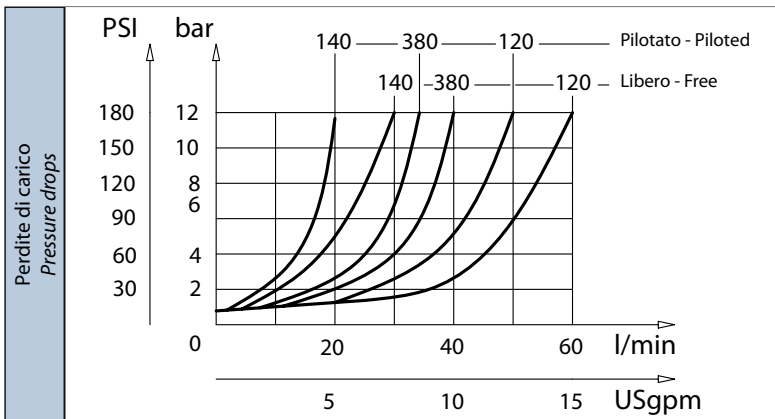

Caratteristiche tecniche Technical performances					
Codice Code	A	Portata Max Max flow l/min - USgpm	Pressione Max Max pressure bar/PSI	Peso approssimativo Approx weight Kg / lb	Rapporto di pilotaggio Pilot ratio
VBCB380	BSPP 3/8	40 (10.5)	350 (5000)	1,1 (2.5)	1:4.25

Codice ordinazione Ordering code					
VBCB - X - Y - K - Z					
X	Dimensione / Size	K	Materiale / Material	Z	Optional
380	BSPP 3/8	S	Corpo in acciaio (Steel body)	S	
Y	Molla - Spring	Incremento pressione al giro Press. increase		Taratura standard Std. setting (Q=5 l/min)	
1	30/210 bar (400/3000 PSI)	70 bar/turn (1000 PSI/turn)		200 bar (2900 PSI)	
2	60/350 bar (850/3500 PSI)	120 bar/turn (1700 PSI/turn)		350 bar (5000 PSI)	